

SUPERRELAX

BLAM
FRENCH SOUND

Driven by passion.

T1020

Tweeter

- 20 mm (3/4") ultra compact soft dome tweeter
- Tooling and compact design created by BLAM
- High efficiency magnet (N38H neodymium)
- High quality special soft dome material



TECHNICAL SPECIFICATIONS

Component	Tweeter	
Max power	30 W	
Nominal power	15 W	
Impedance	4 Ω	
Freq. Response	2.3 KHz - 25 KHz	
Sensitivity (2.83 V/1m)	88 dB	
Magnet	Neodymium	
Magnet size Ø x h	19 x 3 mm	0.748" x 0.118"
Total driver displacement	-	
Weight of one component	0.035 kg	0.07 lb
Voice coil Ø	20,4 mm	0.803"
Voice coil height	2 mm	0.079"
Dome	Soft	

Unit : mm

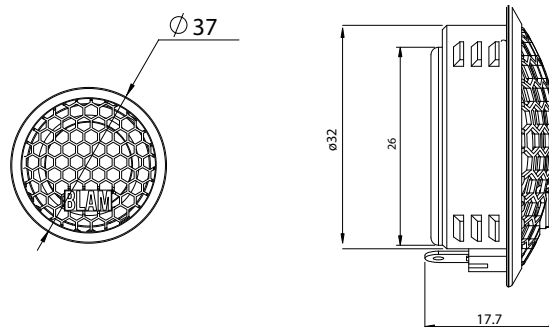

FREQUENCY RESPONSE / IMPEDANCE

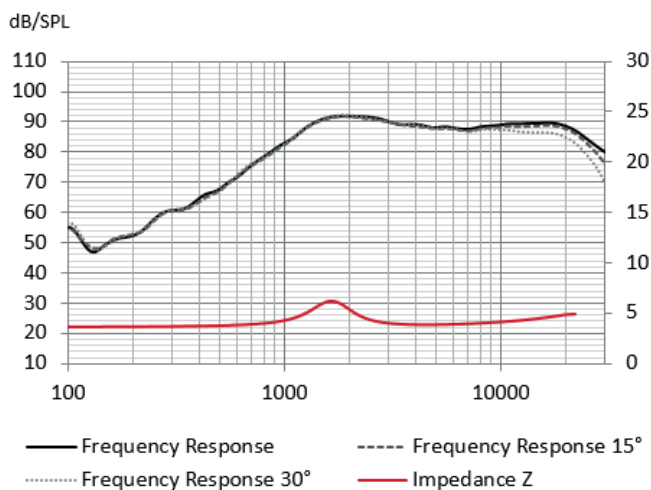

THIELE-SMALL PARAMETERS

Effective Ø (d)	20 mm
Sd	3.14 cm ²
Xmax	-
Re	3.6 Ω
Fs	1150 kHz
Le	-
L2	-
Vas	-
Mms	-
Cms	-
BL	-
Qts	-
Qes	-
Qms	-
Sensitivity (dB/W/m)	87.6 dB

contact@blam-audio.fr
www.facebook.com/blamaudio

blam-audio.com