

Signature

Multix Barrel

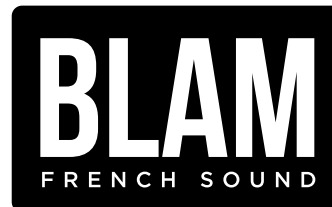

Driven by passion.

T28 MG

28 MM (1") HIGH RESOLUTION TWEETER

The T28MG's pure magnesium diaphragm is stiff and lightweight, allowing the tweeter to operate at high SPLs without distortion. This results in greater sonic clarity even at high volumes.

- 28 mm (1") Pur magnesium dome tweeter
- High efficiency neodymium magnet
- High precision machined aluminium front plate easy to install
- Sound transparent protective grill

TECHNICAL SPECIFICATIONS

Component	Tweeter	
Max power	80 W	
Nominal power	40 W	
Impedance	6 Ω	
Freq. Response	700Hz - 35 KHz	
Sensitivity (2,83V/1m)	91.1 dB	
Magnet	Neodymium	
Magnet size \varnothing	27 x 3 mm	1.063" x 0.118"
Weight of one component	0.076 kg	0.168 lb
Voice coil \varnothing	28 mm	1.102"
Voice coil height	2 mm	0.079 "
Dome	Magnésium	

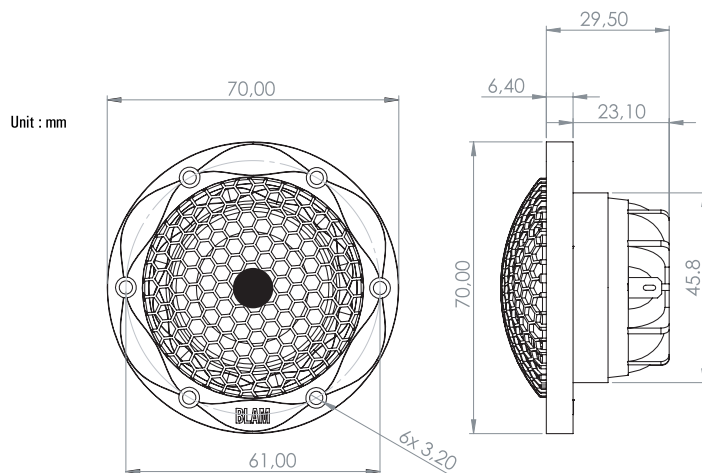

FREQUENCY RESPONSE / IMPEDANCE

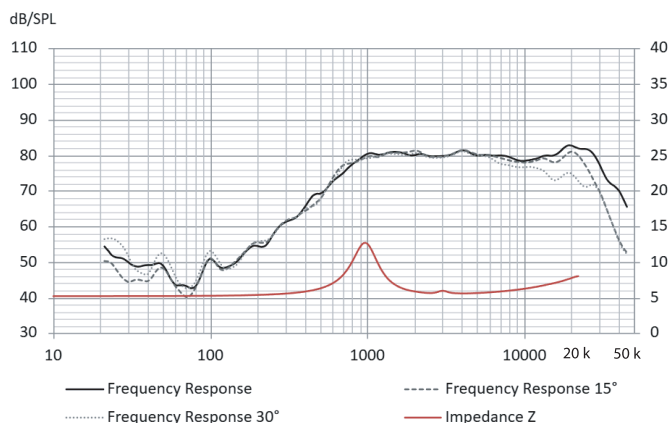

THIELE-SMALL PARAMETERS

Effective \varnothing (d)	30 mm
Sd	9 cm ²
Re	5.1 Ω
Fs	969.73 Hz
Le	-
L2	-
Vas	-
Mms	-
Cms	-
BL	-
Qts	-
Qes	-
Qms	-
Sensitivity (dB/W/m)	89.1 dB

contact@blam-audio.fr
www.facebook.com/blamaudio

blam-audio.com